

## A NEW STUDY OF THE DHAR IRON PILLAR

R. BALASUBRAMANIAM\*

*(Received 4 February 2002; after revision 15 April 2002)*

Various aspects of the Dhar iron pillar have been addressed. The history of the pillar has been first discussed. Dimensional analysis of the pillar has been provided. The original erection methodology of the pillar (by means of inserts and cables) has been addressed. The pillar was not buried underground, but was clamped by three stone boulders, which were themselves held together with iron rings. The microstructure of Dhar pillar iron is characteristic of ancient Indian iron; it contains entrapped fayalitic slag inclusions and a relatively high amount of phosphorus. The corrosion behavior of Dhar pillar iron has been compared with 0.05% C mild steel and another ancient Gupta period (6th Century AD) iron. The Dhar pillar iron exhibited the lowest passive current density in a borate buffered solution of pH 7.6. Samples of atmospheric rust from the Dhar iron pillar have been analyzed by XRD, FTIR and Mössbauer spectroscopy. The results confirmed the existence of crystalline magnetite ( $\text{Fe}_{3-x}\text{O}_4$ ), hematite ( $\alpha\text{-Fe}_2\text{O}_3$ ), lepidocrocite ( $\gamma\text{-FeOOH}$ ), goethite ( $\alpha\text{-FeOOH}$ ) and phosphate and amorphous  $\delta\text{-FeOOH}$  phases. Cross sectional analysis of the rust indicated that there is a thin optically dull layer next to the metal-scale interface and a thick optically bright layer above this.

**Key words** : Corrosion, Dhar iron pillar, Dimensions, Forge welding, History, Manufacture, Microstructure.

### INTRODUCTION

The attention of scientists and archaeometallurgists has not been drawn to the Dhar iron pillar, although this pillar is of larger dimensions than the Delhi iron pillar. Several aspects of the Delhi iron pillar have been addressed in the literature like its corrosion resistance<sup>1,2</sup>, history<sup>3</sup>, manufacturing

---

\* Department of Materials and Metallurgical Engineering, Indian Institute of Technology, Kanpur 208 016, INDIA

technology<sup>4</sup>, presence of lead<sup>5</sup>, decorative bell capital<sup>6</sup> and dimensions<sup>7</sup>. Vincent Smith<sup>8</sup> remarked that “while we marvel at the skill shown by the ancient artificers in forging a great mass of the Delhi pillar, we must give a still greater measure of admiration to the forgotten craftsmen who dealt so successfully in producing the still more ponderous iron mass of the Dhar pillar monument with its total length of 42 feet”. It is currently lying in three broken pieces in front of the Lāṭ Masjid at Dhar (Fig. 1; see also Fig. 11 of Ref. 4). The history of the pillar is first addressed followed by a

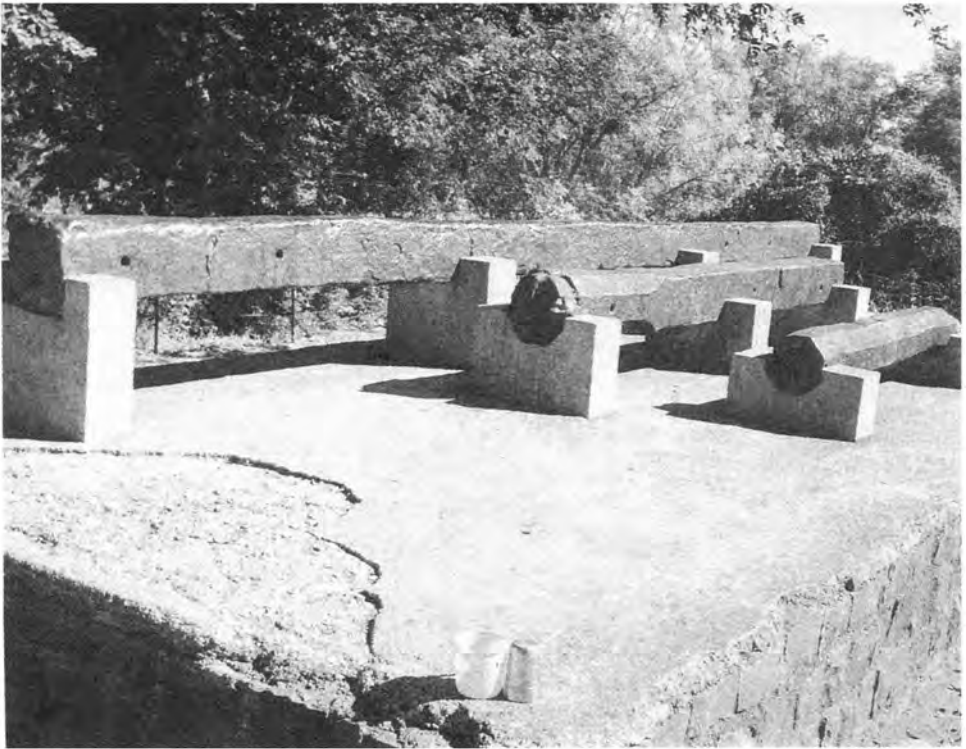

Fig. 1: The three pieces of the Dhar iron pillar. The longest piece is of square cross section, while the second changes from a square to octagonal section and the third piece is octagonal throughout.

description of the structural features of the pillar and its manufacturing methodology. The original erection method of this pillar is also discussed. Finally, a detailed metallurgical analysis (composition, microstructure and corrosion behavior) of Dhar pillar iron is presented.

## HISTORY

Dhar is situated near Indore in Madhya Pradesh and in medieval times, it was the capital of Malwa, when it was called Dhura. The city was founded as capital of King Bhoja (1010-1053 AD)<sup>9</sup>. Dhar suffered the usual vicissitudes of cities in ancient and medieval India and its security depended on the power of its rulers to resist aggression. During the Mohammedan period, it became known as Piran Dhar due to the many Mohammedan saints associated with this place<sup>10</sup>. Dhar first came into Muslim hands around 1300 AD when Allaudin Khilji (1296-1316 AD) subdued Malwa as far as Dhar. Muhammad bin Tughlak (1325-1351) halted at Dhar in 1344 AD and found the whole place desolate due to famine. In 1390 AD, Dilawar Khan was made the governor of Dhar and soon became practically independent in 1405 AD, with his son and successor Hoshang Shah (1405-1435 AD) being the first Muslim king of Malwa. Dhar became second in importance to Mandu, which Hoshang Shah made his capital<sup>10</sup>. Under Akbar (1556-1605 AD), Dhar became the chief town of the *mahal* in the Mandu *sarkar* of the *Subah* of Malwa.

The history of the Dhar pillar is shrouded in mystery. Smith<sup>8</sup> supposes that the Dhar pillar, like the Delhi pillar, was also erected during the Gupta period. There is no inscription on the pillar providing information about its donor and purpose. Prakash<sup>11</sup> mistakenly mentions that there is an inscription on the square part of the pillar, which showed that some southern king Tilungavidya erected a pillar of victory at Ujayapuri. However, there is no such inscription on the pillar and Cousens<sup>12</sup> quoted this inscription (*Epigraphica Indica* Vol. VII, p. 121) to show that the pillar could have been erected as a *jayastambha* (victory pillar). Cousens<sup>12</sup> hypothesized that Raja Arjunavarma Deva (1210-1218 AD) constructed the pillar in 1210 AD with the molten implements of war left in the battlefield by his enemies during his attack on Gujarat, as a mark of victory. Local tradition holds that Raja Bhoja, who was king of Malwa between 1010 and 1053 AD, constructed the pillar. He was a great patron of poets and scholars, and advanced multifarious activities to promote learning. He is credited with more than two dozen scholarly works on a wide variety of subjects<sup>9</sup>. The achievements of the iron industry in Malwa during Raja Bhoja's reign

have been well documented.<sup>13</sup> Bhoja was well versed in iron metallurgy as he, in his *Yuktikalpataru*, discusses the manufacture of iron weapons and refers to earlier texts on iron metallurgy like *Lauhārṇava*, *Lauhadspa* and *Lauhapradīpa*<sup>14</sup>. Moreover, there was a spurt in construction activities during his reign. Bhoja was a Śaivaite (i.e. worshipper of Śiva, one of the trinities of the Hindu pantheon) and this fact would be expressed in the structural design of the Dhar iron pillar, which will be discussed later.

Cousens<sup>12</sup> hypothesized that the pillar was originally set up before the principal temple of Mandu. According to him, the pillar was probably intact before Mandu's capture by the Muslims. There are no archaeological or literary evidences to support Mandu's claim for the original location of the pillar. A strong case, however, can be made for Dhar as the original location of the pillar because it was the capital city of Malwa founded by Raja Bhoja. Probably, the pillar must have been originally topped with a *triśūl* (trident) capital and must have been originally placed in front of a Śiva temple. The probable name of the Śiva temple must have been *Lāṭeśvara*, based on the general name of *Lāṭeśvara Maṇḍala* given to this location within the Malwa region. The use of the word *lāṭ* (pillar) appearing in the name of *Lāṭ Masjid* is also revealing. This temple must have been located at the very site where the present *Lāṭ Masjid* stands. The masonry basement topped with the stone boulders, in front of the *Lāṭ Masjid*, must have been the original erection site of the Dhar iron pillar.

After being thrown down by the Muslims, its shaft was broken into at least two pieces, which lay about for a hundred years. One smaller piece (most probably without the currently missing fourth piece of the pillar) was planted at the Dilawar Khan's mosque in Mandu (in a position similar to that of the Delhi iron pillar in the Quwwat-ul-Islam mosque) based on archaeological evidences. The greater length was erected before the mosque built by Dilawar Khan at Dhar in 1405 AD. He gave the name *Lāṭ Masjid* to the mosque erected by him after the *lāṭ* (pillar) in front of it. The masjid was erected out of the remains of Hindu and Jain temples in 1405 AD. The Hindu and Jain columns in the mosque are handsomely carved, while the *mihirabs* and *mimbar* are fine specimens of Muslim workmanship<sup>15</sup>.

The larger piece remained in front of the Lāṭ Masjid before Bahadur Shah of Gujarat, in 1531 AD, captured the area and wiped out the dynasty at Mandu. The Mughal emperor Jahangir (1605-1627 AD) notes that Bahadur Shah wished to carry the pillar to Gujarat. In attempting to do so, the pillar fell down and broke into two pieces of 22' and 13'. Jahangir writes the following in his autobiography<sup>16</sup> "Outside this fort (of Dhar) there is a Jami Masjid and a square pillar lies in front of the Masjid with some portions embedded in the ground. When Bahadur Shah conquered Malwa, he was anxious to take the pillar with him to Gujarat. In the act of digging out, it fell down and was broken into two pieces (one piece 22' long and the other 13'). I (Jahangir) have seen it lying on the ground carelessly and so ordered the bigger piece to be carried to Agra, which I hope to be used as a lamp-post in the courtyard of my father's (Akbar's) tomb". It is clear that Jahangir's instructions were not carried out as the pillar piece is still at Dhar.

In 1598 AD, Akbar (1556-1605 AD) stopped at Dhar for seven days, while directing the invasion to Deccan. This fact is recorded on the Dhar iron pillar by an inscription of Akbar in Persian. By the way the inscription has been inscribed, it can be concluded that the pillar was lying down rather than upright when the inscription was inscribed<sup>12</sup>. Cousens also remarked about names and letters in Devanagari character on other parts of the largest piece of the pillar. They were engraved with the pillar's proper side up. Among these inscriptions, are several names of visitors of the goldsmith caste each name having "soni" for "sonar" attached to it, and Cousens read the last as "Jasu Soni" for "Yasvant Sonar". The date immediately after the names was very indistinct. These names are between 6'11" and 7'6" from the proper lower end of the largest pillar piece. All the Devanagari letters and names are about the same level, and none occur on the upper parts of the largest pillar piece or on the other two pieces, which clearly indicates that these characters were engraved before the first fall of the pillar. Cousens<sup>12</sup> noticed several small symbols and a Persian word or two, but they were all rather scratched in rather than engraved.

The largest piece (i.e. the one that Jahangir measured as 22' and which had broken off from the erected pillar in front of the Lāṭ Masjid) remained

in the same position from the time of its fall in 1531 AD, when Bahadur Shah tried to remove the pillar, till the time it was removed by the Archaeological Survey of India (ASI) around 1980 AD and placed horizontally on a platform adjoining the mosque (see Fig. 11 in Ref. 4). The reports by Führer<sup>15</sup> and Cousens<sup>12</sup> show that it was lying in the same sloping position against the masonry terrace in front of the mosque (Fig. 2), just as Jahangir had described. Interestingly, the kids in the nearby areas were utilizing this piece as a slide (before the ASI set it up on the platform) and therefore, the top surface of the largest piece appears smoothly polished.



Fig. 2: Photograph taken in the early 1900s showing the longest piece of the Dhar iron pillar lying in a sloping position against the masonry terrace in front of the Lāṭ Masjid. This piece remained in this position from 1531 AD till about 1980 AD. Photograph courtesy: Archaeological Survey of India.

As regards the second piece that was broken during the time of Bahadur Shah, Führer<sup>15</sup> mistakenly reports that it was standing outside

the Jami Masjid in Mandu. Both Campbell<sup>17</sup> and Smith<sup>8</sup> have presented Fuhrer's incorrect observations. (The iron pillar standing outside the Jami Masjid in Mandu, even today, is the iron flagstaff known as Allaudin's *Sang* (spear) and this pillar will be described in Appendix I. The second piece was lying within Dhar. Cousens, in February 1903, saw the same at the Anand High School, where a museum had been established sometime in 1902. This museum was shifted to another location within Dhar sometime between 1922 and 1942. The second pillar piece was not shifted to the museum at the new location but was placed horizontally on the ground, without any support, near the masonry basement where the longest piece lay. This piece was removed from this position by ASI, around 1980 AD, and placed horizontally on concrete supports on a platform near the mosque (Fig. 1).

One of the originally broken pieces that was originally erected in the Dilawar Khan mosque in Mandu was also moved from this location during the British period, as stated by Cousens<sup>12</sup>. He quotes the following interesting account of the sighting of the third piece at Mandu by a Bombay subaltern published in 1844: "there is a large piece of iron several tons in weight—a remnant of the blacksmith's stock-in-trade, which he forgot to convert into gold". Cousens<sup>12</sup> mentions that this account refers to the smallest piece of the *lāṭ* that was subsequently brought down to Dhar. Fuhrer<sup>15</sup> states that the smallest piece was in the garden of the Maharaja's Guest House at Dhar in 1893 (which was later called the Agency House and currently a heritage hotel), while Cousens reports, that in February 1902, this was fixed in a masonry basement in the public gardens known as *Lāl Bāgh*, quite close to the Anand High School. Cousens had this pillar piece removed from the masonry basement in order to determine its accurate dimensions. It was then placed in the museum at Anand High School and, similar to the second piece, was shifted to its current location. Therefore, this piece has also been shifted from one location to another in Dhar, after being brought down from Mandu.

The three pieces of the Dhar iron pillar are currently lying horizontally on concrete supports on a platform beside the *Lāṭ Masjid* (Fig. 1).

## DIMENSIONS

Führer<sup>15</sup> first reported that the largest piece was 24' long and 10" on each side, while the second piece was 12' long and the third, 6' long. He mistakenly quotes the third piece as a square cross section of 10" width. Smith<sup>8</sup> quotes Führer's measurements *verbatim*. Cousens<sup>12</sup> reported that the total length of the three pieces was 43'4", with an average cross section 10.25". The longest portion was measured as 24'3" of square section; the second 11'7" (of which 8'6" was square and 3'1" was of octagonal section); and the third piece, 7'6" in length, and, with the exception of a circular collar at the end, about 8" deep, was of octagonal section throughout. He also reported that the proper lower end of the largest piece was slightly bulbous (see Fig. 1), being about 11" wide at 2' from the end, while the rest of the cross section measured 10.25" to 10.50". Prakash<sup>11</sup> and Roessler<sup>18</sup> also measured pillar parts. Roessler mentions that the first and the biggest part of the pillar possessed a length of 24'2" with a nearly square section of 10'7" ( 11'1". The second piece was 11'8" long with a rectangular section of 10'7" ( 10'2" over a length of 9'2", then changed into an octagonal cross section and finally ended with a cone shape of 5.5" length and 9.5" diameter. The third part of the pillar was 7'6" long and is octagonal, beginning with a cone shape of 8.3" length and 9.5" diameter<sup>18</sup>. The combined height of the pillar has been estimated to be 43'4" and this is nearly double the height of the Delhi iron pillar. Roessler estimated the weight of the three parts, utilizing the measured dimensions and the specific weight of iron (7.81 g/cm<sup>3</sup>), as 4.50 tons for the largest piece, 1.86 tons for the second and 0.94 tons for the third piece, thereby providing a total weight of 7.3 tons. Therefore, the combined weight of the Dhar iron pillar is at least a ton more than the Delhi iron pillar.

As regards the original joints of the pillar, the matching fracture surface of the top of the largest piece and the bottom of the second piece (Fig. 3) proves that both these parts of the pillar were originally joined together when manufactured by forge welding process. However, the conical top of the second piece (Fig. 4a) and the conical bottom of the third piece (Fig. 4b) do not seem to be joined by forge welding. Roessler<sup>18</sup>, based on the original idea of Cousens<sup>12</sup> of a collar connecting the two pieces,



showed that the third part of the pillar was joined with the second part of the pillar by a forged ring (Fig. 5). Roessler proposed that the ring could have been of the same dimensions as the octagonal portion. Cousens<sup>12</sup>



Fig. 3: The matching fracture surfaces of the top of the largest piece and the bottom of the second piece

stated that he has “personally taken fresh measurements of the two smaller sections, as a doubt was expressed as to their both having been parts of the same pillar. The smallest piece, with the collar or neck at one end, measures 2' 9.5" round its octagonal shaft, while the other measures 3' 2" round the octagonal end. The first gives  $10\frac{1}{4}$ " diameter from one face to an opposite face, through the pillar, and the breadth of the square shaft of the largest section at the Lāṭ Masjid is  $10\frac{3}{8}$ " at its upper end, while the breadth of the square part of the middle section is  $10\frac{1}{8}$ ". The width then of the smaller section is practically the same as the square part in the other two sections.

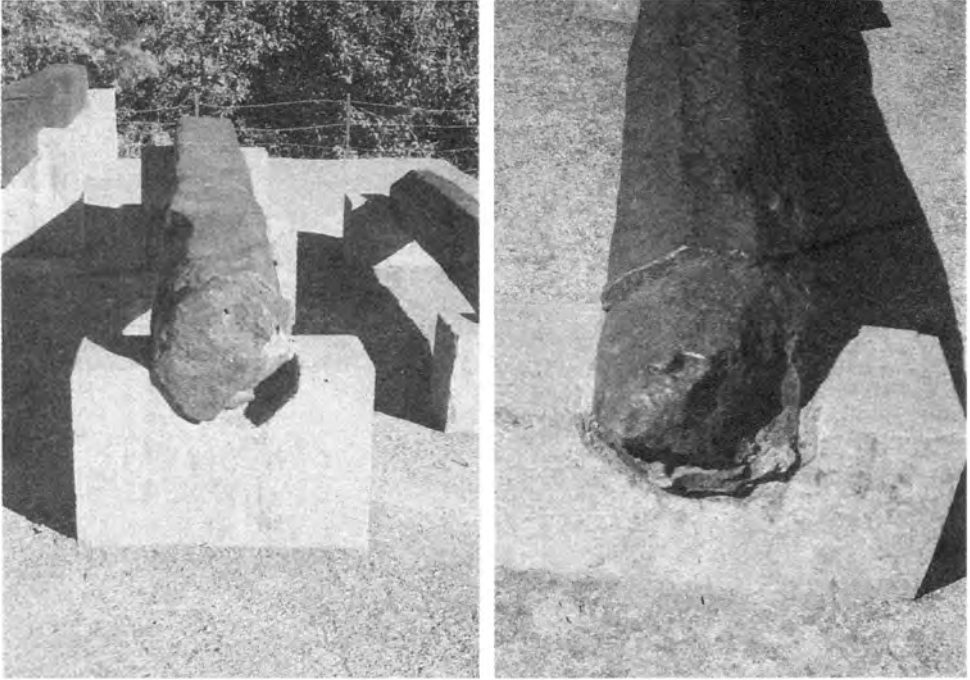

Fig. 4: (a) Conical top of the second piece, and (b) conical bottom of the third piece.

But the perimeter of octagonal end of the middle piece gives a diameter of  $11 \frac{3}{8}$ " , which shows how unequal the diameter is in different parts. It seems quite clear, however, that the shortest piece does not immediately join on to the middle piece as there would be a sudden lessening from  $11 \frac{3}{8}$ " diameter to  $10 \frac{1}{4}$ " , and I think we must conclude that there is a missing piece which fitted between these." He further goes on to state that the conical ends of the second and third pieces must have been intended to hold a collar.

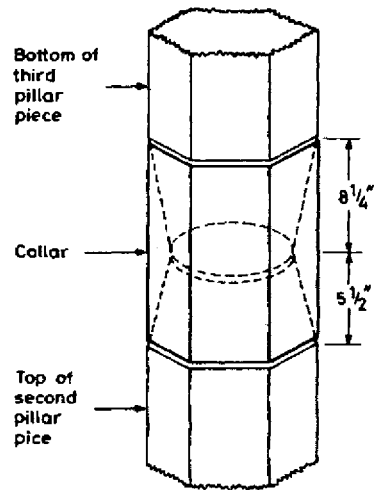

Fig. 5: Proposed joining methodology of the second and third pillar pieces using a collar<sup>12,18</sup>.

The fractured top of the third section (Fig. 6) indicates a missing fourth piece of the pillar. The relatively higher percentage of slag inclusions on this fracture surface should be noted. This must be the reason for the fracture at this location when the erect pillar was first thrown down. Based on the fact that the proportion of the octagonal part of the whole pillar to the square portion required greater length in the former, Cousens<sup>12</sup> proposed that the total length of the original pillar was probably a little short of 50'.

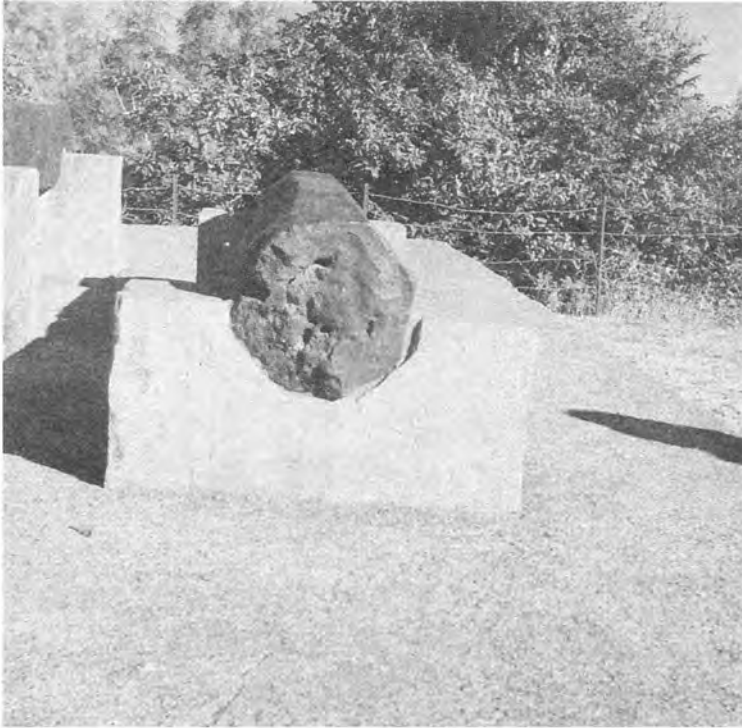

Fig. 6: Fractured top surface of the third piece indicates that a missing fourth piece was present atop the third piece.

On the other hand, Roessler<sup>18</sup> deduced that there must be a missing fourth piece (about 3'3" in length) based on the relative position of the drill holes in the third piece. The size and complete cross section of the missing part is not known with the available information. However, it has been speculated that it could be octagonal or octagonal-round<sup>18</sup>. This discussion on the missing fourth piece reveals that the Dhar iron pillar must have been higher than 43'4".

Cousens<sup>12</sup> first hypothesized that the pillar was surmounted by either a *garuḍa* or a *trīśūl*. Führer<sup>15</sup> notes that the “third piece, a square of 10 inches, with a bell- capital, 6 feet high, is standing in the garden of the Maharajah’s guest-house at Dhar.” Cousens enquired about this in a letter to Mr. Lele, the State Superintendent of Education, stationed at Dhar. Mr. Lele replied that he, as soon as he received the letter, “drove to the Agency House and made a search for bell-capital near the Havaladar’s house. Nothing like it was found there or anywhere else. But on further enquiries I found, near the *baghban*’s house, a flat octagonal slab of ordinary black-stone, which old people say rested upon the *lāṭ* while it was standing in the Agency



Fig. 7: Bell-shaped structure currently lying at the Dhar fort museum. Roessler<sup>18</sup> proposed that this was the original decorative bell capital of the Dhar iron pillar.

garden. It formed the seat of a stone Figure of Napoleon Bonaparte on horseback by which the *lāṭ* was surmounted. When Führer visited Dhar this slab with its support might have appeared to him bell-shaped.” Roessler<sup>18</sup> observed a bell-shaped structure (Fig. 7) at the Dhar fort museum

and proposed it to be the capital of the Dhar iron pillar. The author was also present during Roessler's trip to the Dhar fort museum. In the author's opinion, the bell-shaped structure appears to be the end-part of a forge welded cannon. There are numerous forge welded iron cannons in the Dhar fort and the bell-shaped structure must have originated from one of these cannons. In summary, although it is proved that there is a missing fourth piece, the nature of this piece and the pillar's capital are not known.

In order to understand the missing fourth piece and the probable capital of the pillar, recourse will also be taken to Hindu iconography. As the pillar was set up by Raja Bhoja, it is clear that it must have formed a pillar in a Śiva temple. As a staunch Śaivaite, Raja Bhoja<sup>9</sup> constructed several temples dedicated to Śiva. Firm support for the pillar being associated with a Śiva temple is obtained from the observed cross sections of the Dhar pillar. In Hindu iconography<sup>19</sup>, Śiva is depicted as *Śivaliṅgam*, symbolically represented by an erect phallus. The *Śivaliṅgam* consists of three distinct parts. The lower part of the *Śivaliṅgam* is square in cross section indicating the *Brahma Khaṇḍ* (The Portion of Brahma – God of Creation). This changes to an octagonal cross section, which is indicative of *Viṣṇu Khaṇḍ* (The Portion of Viṣṇu – God of Existence). Finally, the cross section changes to circular in the upper regions, which is indicative of *Rudra Khaṇḍ* (The Portion of Śiva – God of Destruction). The resemblance of the pillar to the *Śivaliṅgam* in symbolic terms is to be noted based on the square and octagonal cross sections of the pillar. Therefore, it can be concluded that the final cross section of the pillar in the missing fourth piece must have been circular, based on the iconographic description of the *Śivaliṅgam*. It is, therefore, probable that the pillar must have originally surmounted by a *triśūl* or trident, which is the symbol (standard) of Śiva.

In order to glean ideas about the original condition of the pillar, insights will be obtained by dimensional analysis of the Dhar pillar. Analyzing the relative lengths of the various cross sections, it is noted that the square cross section extends to a total distance of 33' and the octagonal cross section, in total, is about 11'. Therefore, the octagonal cross section must have formed a certain proportion of the original square cross section and it is reasonable

to assume that this was one third of the square cross section height, which is symbolic of the trinity concept in Hindu pantheon iconography. The circular section must have been again one third of the length of the cross section below it (i.e. the octagonal section) and therefore, based on the analysis above, its height must have been about 3'. This dimension fits well with the estimates of Cousens<sup>12</sup> and Roessler<sup>18</sup> who stated that the missing fourth piece should have been about 3' in length. Finally, the relative dimension of the pillar capital should appear at a fixed proportion to the pillar body and it is again reasonable to assume that this must have been one third of the height of the cross section just below it and therefore, it is deduced that the *trīśūl* capital should have been 1' in height. With the above-deduced dimensions, the total height of the original pillar must have been 48'. The dimensional analysis described above has been reproduced in the schematic depiction of the possible original condition of the Dhar pillar (Fig. 8).

It is probable that the iron pillar currently standing at Mandu (in front of the Jami Masjid) could have been the missing fourth piece of the pillar. First, the pillar is of circular section which is indicative of the final cross section of the Dhar iron pillar. Second, this pillar is associated with Allaudin Khilji as it is presently called *Allaudin's Sang* (spear). As noted earlier, Allaudin Khilji was the first Muslim ruler to plunder interior Malwa and therefore, the first fall of the Dhar iron pillar must have occurred during his raids. It is probable that Khilji could have

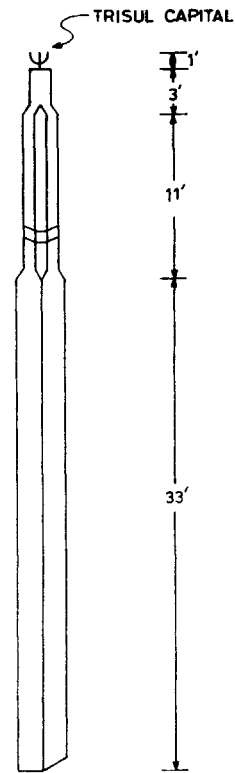

Fig. 8: Schematic representation of the original condition of the Dhar pillar, showing the relative dimensions of various sections of the pillar. The circular cross section of the final top regions of the pillar and its *trīśūl* capital have been deduced based on Hindu iconographic philosophy.

modelled the fractured circular part of the pillar in the form of the pillar currently seen in front of Jami Masjid at Mandu. It is also interesting to note a large joint towards the top of the Mandu iron pillar, a probable location from where the *triśūl* capital of the pillar must have been re-shaped to form the presently-seen circular section. This iron pillar seen in front of the Jami Masjid in Mandu is described in greater detail in Appendix I.

### ERECTION OF THE PILLAR

Cousens<sup>12</sup> first mentioned the presence of a number of small holes (see Fig. 1 and 2) at irregular intervals on all its four sides, varying in depth from 1 ¾ " to 3", and in diameter about 1 ¼". They run up each of the four sides of the square shaft and the corresponding faces of the octagon. The unequal distribution of the holes discounts the possibility of the pillar having been a *dīpadāna* (lamp-post) and Cousens<sup>12</sup> supposed that these pits were used for the purpose of inserting some instrument like crowbars while the pillar was being forged and welded. With the aid of these crowbars, it was suggested that the workmen could easily manipulate the heavy column and forge weld the semi molten metal, lump by lump, on to the white hot stump of the shaft. Cousens did not mention the material and the length of the crowbar, while Roessler<sup>17</sup> proposed that it was made out of steel. Prakash<sup>11</sup> has also noted these small holes and related them to the manufacturing methodology. His views will be discussed while addressing the manufacturing methodology of the pillar. Roessler<sup>18</sup> mentions that all the pieces contained holes of 1.2" to 1.6" in diameter and 1.6" to 3" deep, and that the holes were distributed at irregular distances on all 4 sides of the first and the second pillar. Two holes in the front (arrowed in Fig. 9) and back of the third piece are partly closed by the concrete support beams. The arrowed hole in Fig. 9, at a distance of 1.6" from the upper surface of the third pillar piece, is partially closed because a broken peg/crowbar is seen at this location. Cousens<sup>12</sup> and Roessler<sup>18</sup> have noticed this half-closed hole. Compositional analysis of the broken peg/crowbar from this location would provide insights on the material of construction of the peg/crowbar.

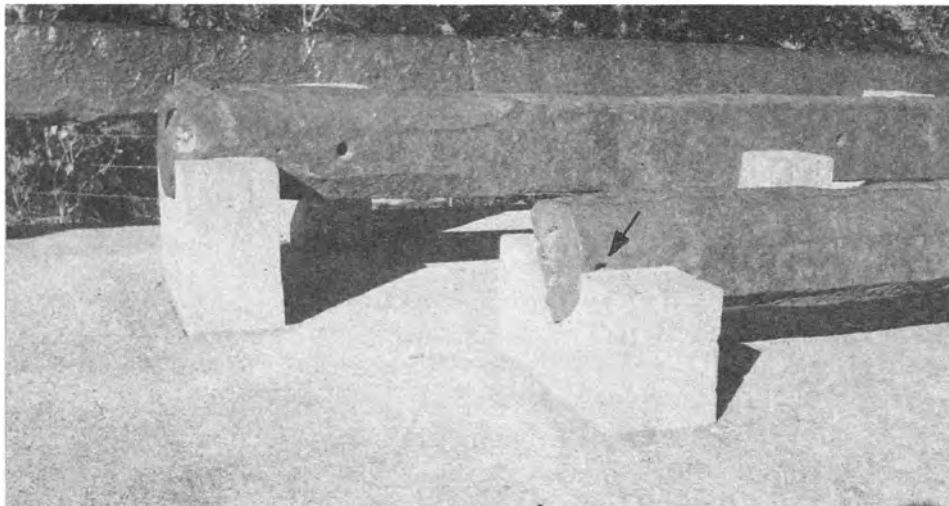

Fig. 9: Two holes are present in the front (arrowed) and back faces of the third piece and they are partly covered by the concrete support beams.

Roessler has provided a plausible explanation for the existence of these holes. He states that the pillar would have been impossible to fix in the stone stand (to be discussed below) due to the heavy weight of the pillar and its tremendous height. Roessler proposed that the holes, apart from being used for handling the pillar during the manufacturing process, were inserted with small pegs in order to fix cables or wires at different heights of the pillar in order to hold the pillar in the upright position. The probable reconstruction of the pillar in the upright position, as suggested by Roessler<sup>18</sup>, is provided in Fig. 10. The proposal for the reconstruction was based on the estimation of the bending moment resulting from the weight

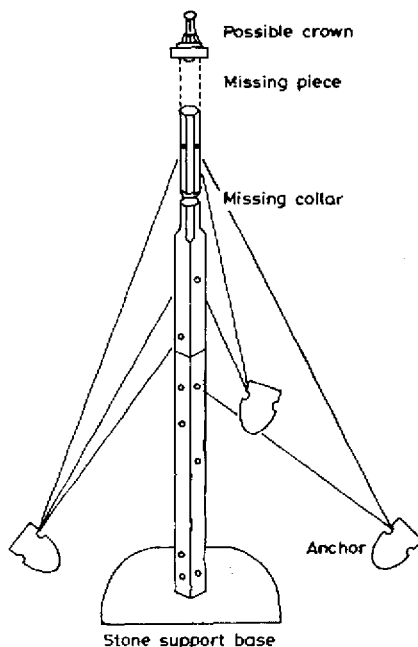

Fig. 10: Proposed reconstruction of the Dhar iron pillar according to Roessler (1995).



of the pillar multiplied by the center of gravity (nearly the half the height of the pillar). Based on the existence of an ancient iron anchor near Jahaz Mahal at Mandu, Roessler<sup>18</sup> further proposed that the cables were held in position by means of iron anchors (Fig. 10). However, this may not be likely as the ancient iron anchor at Mandu (Fig. 11) was used for anchoring the boats that sailed in the lake adjoining the Jahaz Mahal at Mandu.



Fig. 11: Iron anchor originally discovered from the lake adjoining Jahaz Mahal in Mandu. Its height is 30.7" and width at the top 22" and at the bottom 11.8". Its thickness is 6.3" at the bottom and 7" at the top.

The lower region of the Dhar iron pillar was not buried underground when it was originally erected, unlike the Delhi iron pillar. Cousens<sup>12</sup> first reported the method by which the pillar was erected originally. Opposite

to the Lāṭ Masjid, there are three pieces of stone on a masonry basement (Fig. 12a). Cousens<sup>12</sup> in 1902 observed that iron rings were used to bind

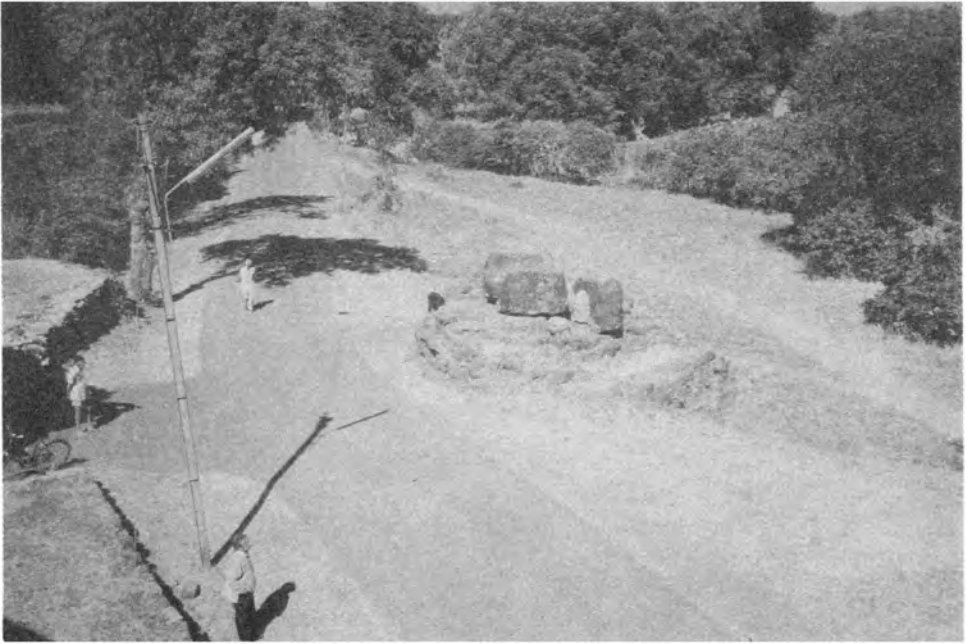

Fig. 12: (a) Three stone boulders currently on the masonry basement opposite the Lāṭ Masjid;

together the three rock boulders together. He states, “upon the masonry basement stand the three great rock boulders, which were bound together by iron bands and had a socket in the top, 20 inches deep (Fig. 12b and 12c), where the foot of the pillar was gripped. The iron bands securing these passed round them horizontally, and their pressure was spread over the boulders by vertical flat iron bars inserted at intervals under the bands in slots cut for the purpose. In-fact the whole was faggotted around the end of the pillar.” The slots for inserting the vertical flat iron bars can be noticed on the stone blocks (Fig. 12b). The iron bands and the flat iron bars are currently missing. The bottom surface of the Dhar iron pillar possesses a circular hole of 2.3” in diameter and 3.8” in depth (see Fig. 17 of Ref. 4) to hold an insert for gripping the bottom of the pillar with the stone boulders. Additionally, the circular holes seen in the bottom region of the pillar (Fig. 13) must have been used for securing the pillar with the stone basement with the aid of inserts and ropes. Interestingly, the stone boulders themselves have circular holes provided at their bottom for gripping them to the platform (Fig. 14).

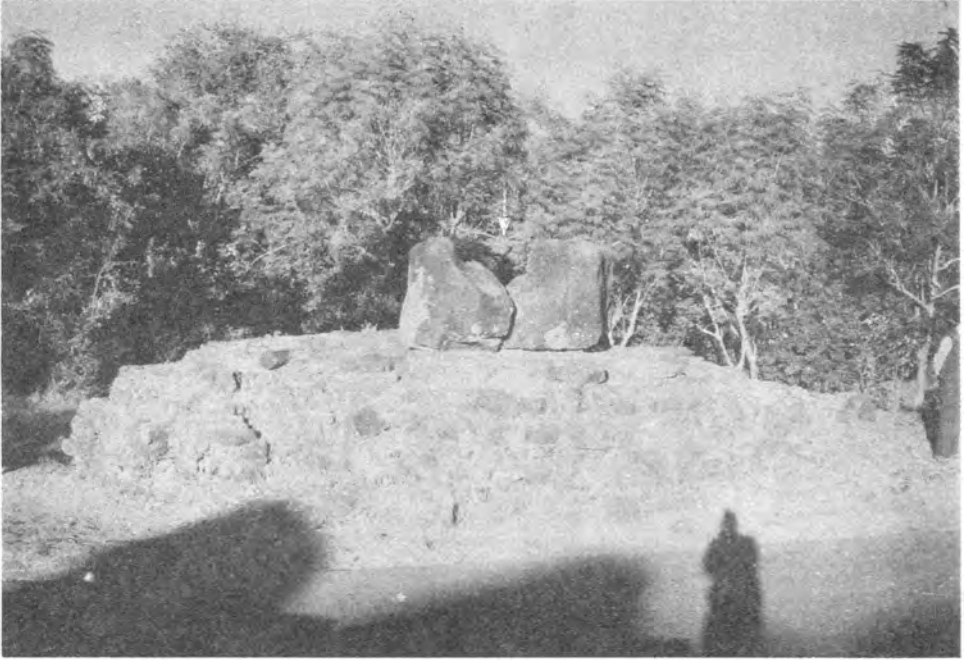

Fig. 12(b). The 20" deep socket in the middle of the three stone boulders (arrowed), in which the bottom of the pillar was originally gripped.

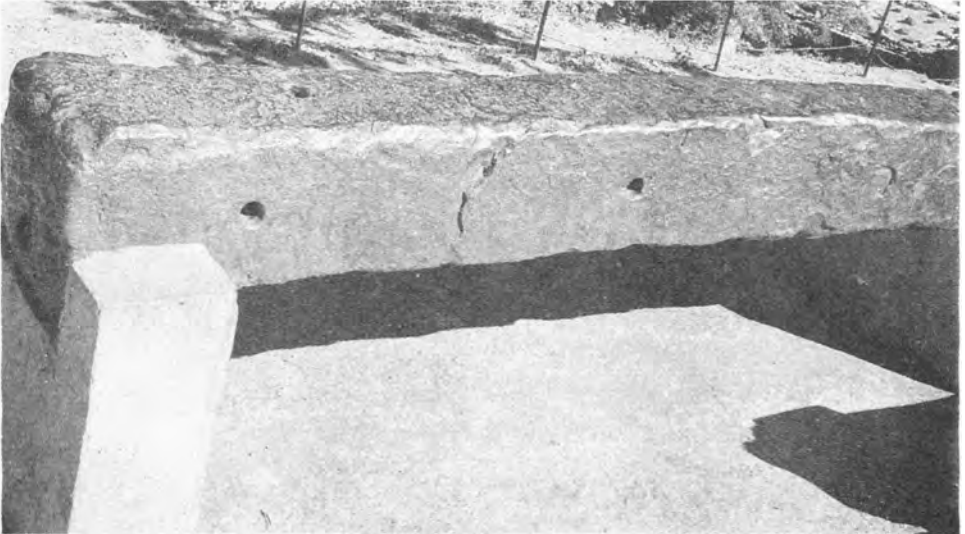

Fig. 13: Hollow holes in the bottom region of the Dhar iron pillar. These hollow slots were used for gripping the pillar to the basement by means of inserts and ropes.



Fig. 14: Hollow cylindrical slot provided at the bottom of one of the stone boulders that were originally used for holding erect the Dhar iron pillar. This hollow slot was used also for gripping the stone boulder to the masonry basement by means of an insert, similar to the pillar clamped with an insert to the stone boulders.

### MANUFACTURING METHODOLOGY

The iron pillar has been forge welded by the horizontal forge welding technique, as outlined for the construction of the main body of the Delhi iron pillar<sup>4</sup>. The surface is not as well forged as the Delhi iron pillar. Roessler<sup>18</sup>, however, admired the forge welding methodology by noticing that "at the bottom of the longest part there is a perimeter of 3'8", in the middle 3'7" and on the top 3'5", which means the square is reduced by only 0.4" each side from the top to the bottom of the 24'2" height pillar. It shows the exactness of the forging."

Prakash<sup>11</sup> provides an interesting alternative account of how the pillar may have been manufactured. He notes that the four surfaces of the first section and the square part of the second section are covered with flat plates

2" to 6" thick and 2' to 2'4" long. He further states that the holes have been punched about 2" to 4" before the end of each of these plates and in the process deforming them and piercing into the main body (Fig. 15a). He concludes that the pillar has been fabricated by joining 2'4" to 2'9" long pieces of square cross-section and the plate have been fixed and forge welded as butt welded re-enforcement on the joints. He also suggested the horizontal forge welding technique for fabrication of the other pieces of the pillar, while ruling out the possibility that the cross-section was changed by chiseling out the excess material to give the desired shape. As noted earlier while discussing the manufacturing methodology of the Delhi iron pillar<sup>4</sup>, the possible presence of a thick circular pin in the fractured end of the first piece can be noted (see Fig. 12 in reference 4). Prakash attributed the fracture of the pillar to improper forge welding technique due to insufficient pressure and to the presence of a higher amount of slag inclusion in the Dhar pillar iron. He proposed that the iron required for construction of this pillar was smelted near Ujjain and first forge welded into square blocks of 2'4" to 2'9" and then transported to Mandu or some nearby area for final fabrication. These hot forged square sections were supposed to possess a circular tapered hole in the center of the square cross-section, with the holes (of 1.6" to 2.4" diameter) being punched in to these blocks in ret hot condition. In the second stage of manufacture, Prakash envisaged that these 2'4" to 2'9" long sections were joined together in the hot condition by fixing a common iron pin and forge welding two adjoining faces (Fig. 15b). He further speculates that for handling the hot sponge, highly skilled craftsmen must have used forging hammers weighing 20 to 40 kg, based on his observation of such heavy swing forge hammers in operation in the cottage industries for producing heavy forgings. The possibility of drop forging methodology was also mooted by Prakash<sup>11</sup>. In this way, Prakash proposed that several 2'4" to 2'9" long sections were joined together to fabricate a long pillar or shaft which was further forged in the horizontal position to give it a proper shape. As noted earlier, Prakash proposed that the joints were further strengthened by butt welding of the iron plates by first forge-welding these plates on the joint and later securing them in position (as well as weld them with the main body) by hammering a cold punch through the hot stock under heavy pressure (Fig. 15a). This,

according to Prakash<sup>11</sup>, was the reason for the holes noticed on the pillar. He also accepts that these holes must have further facilitated the handling of the iron shaft, as originally suggested by Cousens<sup>12</sup>. Ultrasound measurements by the author and Roessler, conducted in December 1996, using a hand-held ultrasound equipment did not provide conclusive evidence for the presence of the surface plates. The largest pillar piece does show large weld joints spaced at about 2'4" to 2'9" (Figures 1, 3 and 13). Moreover, the plate-like structure of the faces can be noticed in the bottom cross section of the second piece and top cross section of the first piece (Fig. 3). Therefore, the manufacturing method proposed by Prakash<sup>11</sup> needs to be looked into carefully in future studies of the pillar. However, there is no doubt that the Dhar iron pillar has been manufactured by the horizontal forge welding technique<sup>4</sup>.

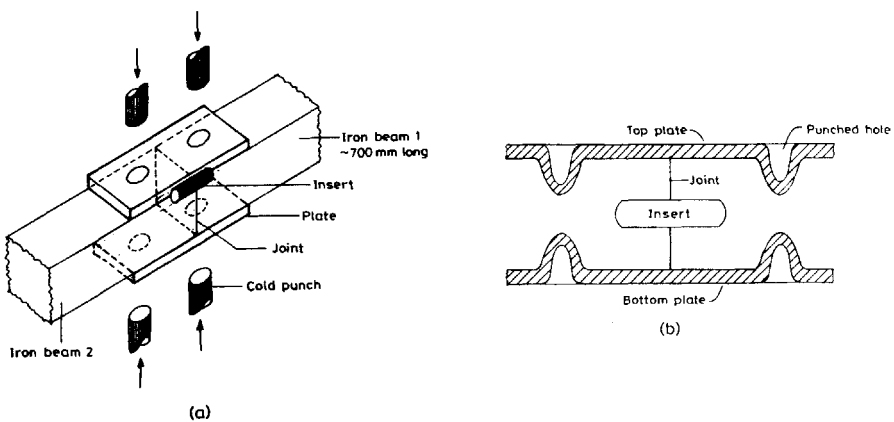

Fig. 15: The method of joining the iron blocks and butt welding of the plate on the pillar surface, as proposed by Prakash (1989): (a) isometric view, and (b) cross-section.

Finally, it is important to join the three parts of the Dhar pillar, for which sophisticated welding techniques are currently available. The Dhar pillar in the completed state would be the largest ancient forge welded iron pillar in the world.

## CORROSION RESISTANCE

There is only one published composition of the Dhar pillar iron. According to Tylecote<sup>20</sup>, with a quotation of Hadfield<sup>21</sup> and Graves<sup>22</sup>, the chemical composition of Dhar pillar iron is 0.02% C and 0.28% P. A small piece of the Dhar iron pillar was obtained from the lower face of the second largest pillar piece, with the permission of ASI, and characterized<sup>23</sup>. As the Dhar iron pillar is a product of forge welding, there was one location where the small piece of metal in the form of a thin sheet about 0.1" thick was protruding out of the surface. A chisel was used to gently ease out this flat piece of metal without damaging the surface of the pillar. This piece of Dhar pillar iron was used in all further studies reported here. Local compositions were determined using an 8600JXA JEOL electron probe microanalyzer (EPMA). The composition varied from one location to another, depending on the microstructure. The composition from one region (containing pearlite) was (in weight percent) 0.683% C, 0.693% P, 0.013% Mn and no sulphur, while from another location (containing both ferrite and pearlite), the composition was 0.276% C, 0.851% P and 0.075% Ag. Interestingly, the Ag content was insignificant in all the locations analyzed. Cousens<sup>12</sup> commented that the local people believed that the pillar was made of *pañcarasa* or *aṣṭadhātu*, an alloy of five or eight metals. He speculated that some bright appearing regions on the surface was silver, imperfectly mixed with iron from the silver-mounted weapons. A detailed compositional analysis of the pillar is required to determine whether Ag is present in significant amounts or not. The relatively higher amount of P in Dhar pillar iron must also be noted. The entrapped slags were also analyzed and it was found that they were essentially fayalitic. A typical composition obtained was 55.8% Fe, 27.8% Si, 0.1%Mn and 16.3% P.

Microstructural analysis indicated that there were some regions devoid of carbon (Fig. 16a); while at other locations there was a significant amount of carbon as revealed by the presence a higher volume fraction of pearlite (Fig. 16b). The entrapped slag inclusions were generally surrounded by a higher volume fraction of pearlite (Fig. 17). This aspect has been discussed in detail in Reference 24. The presence of a significant amount of P was also revealed by the characteristic "ghosting" effect following nital etching (Fig. 18), which is typical of iron containing phosphorus<sup>25</sup>. The "ghosting"

phase is a differential etching effect resulting from local phosphorus enrichment and this phase is commonly observed in phosphorus-rich ancient Indian iron. Interestingly, the fracture surface of the iron piece

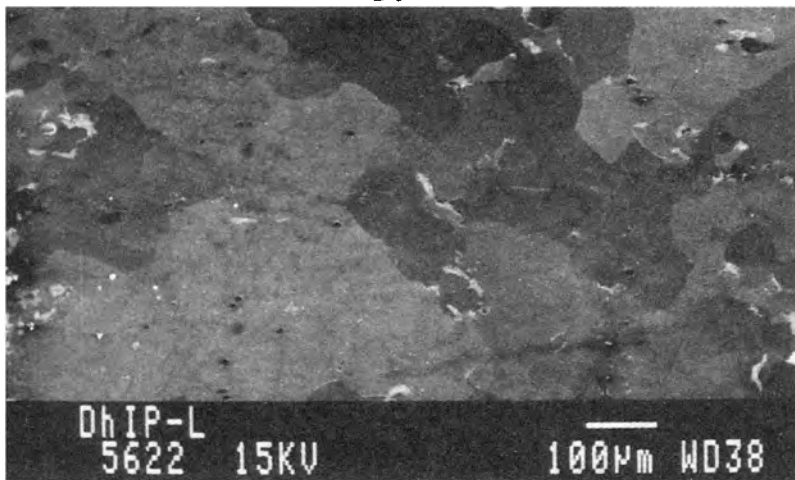

Fig. 16 (a) Scanning electron micrograph of Dhar pillar iron showing typical region, devoid of carbon.

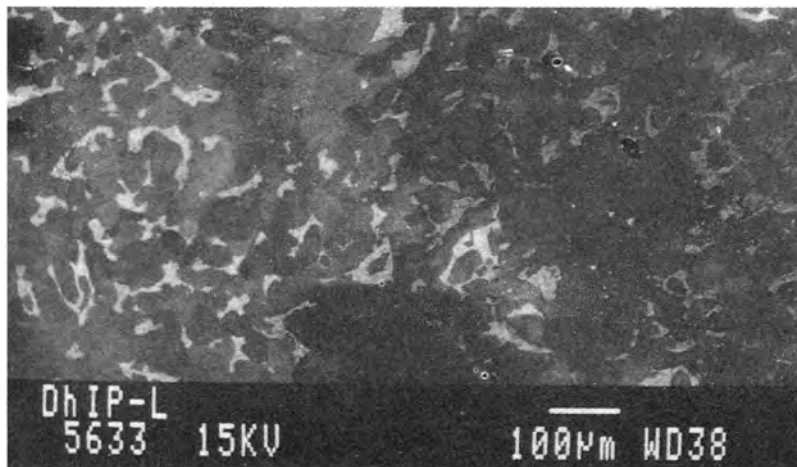

Fig. 16 (b) Scanning electron micrograph of Dhar pillar Iron containing significant amount of carbon.

indicated brittle intergranular failure in several locations (Fig. 19), which is suggestive of P segregation to the grain boundaries and their subsequent embrittlement. The tendency for P to make iron cold-short (i.e. susceptible to brittle fracture during cold working) is well known<sup>25, 26</sup>.



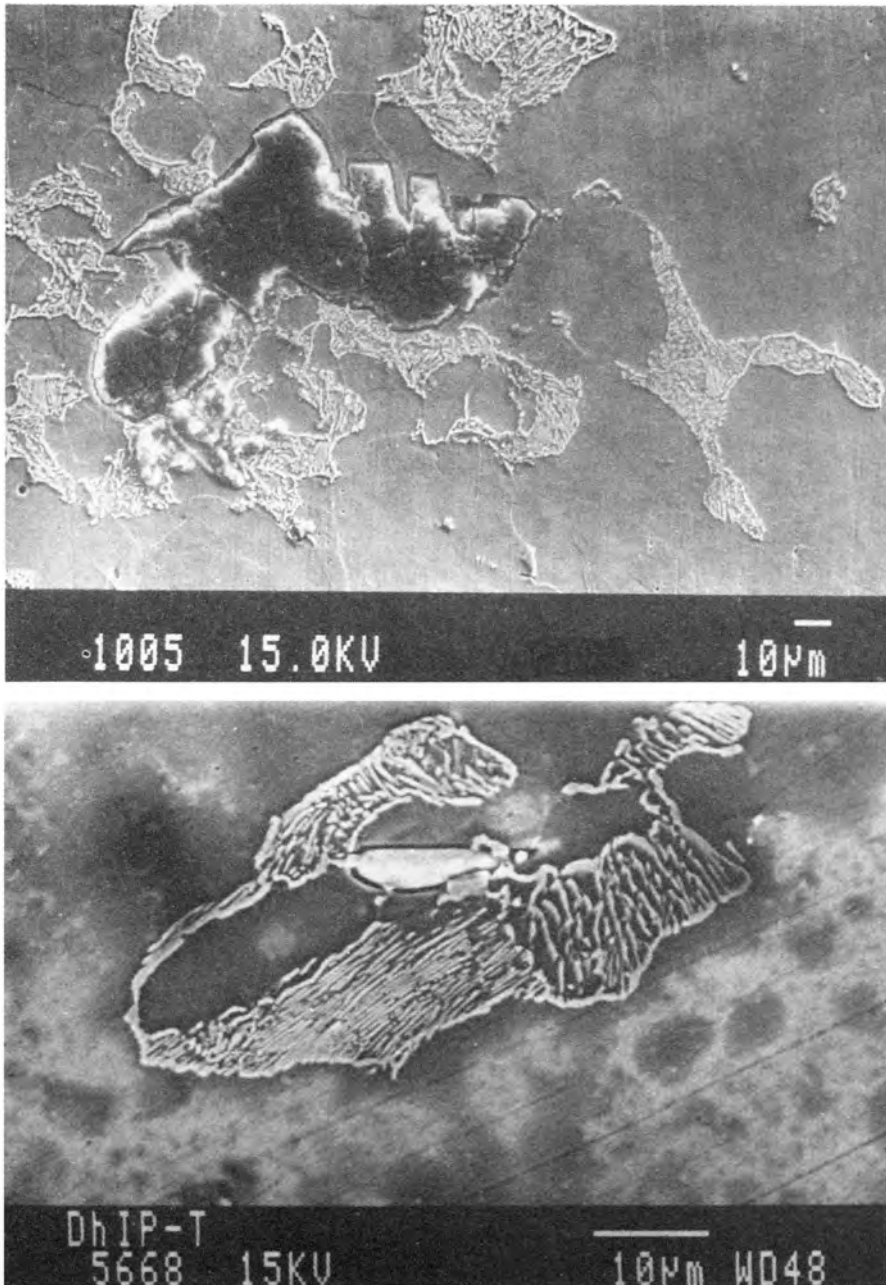

Fig. 17 (a) & (b): Microstructures of Dhar pillar iron showing the presence of a larger fraction of pearlite near slag particles.

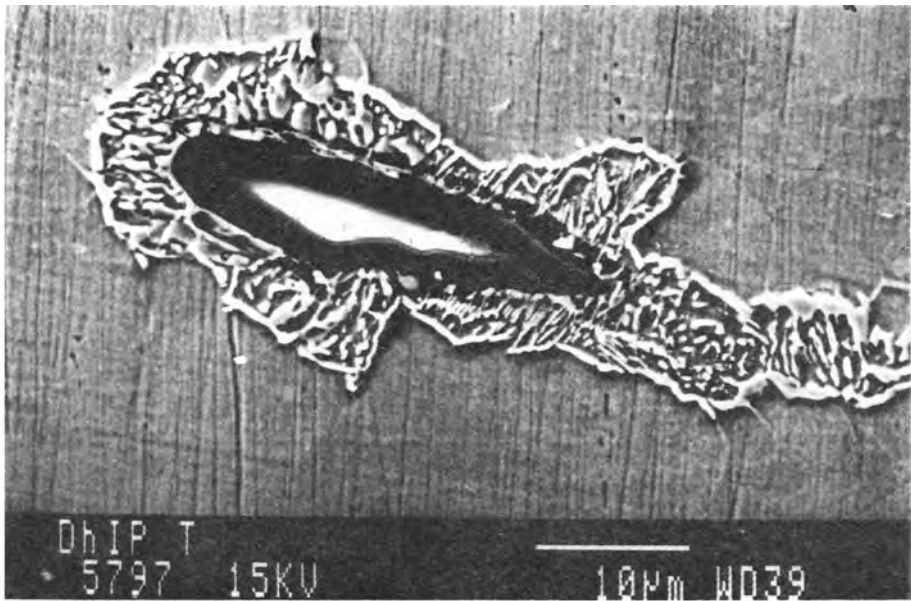

Fig. 17 (c) Microstructures of the Dhar pillar iron showing the presence of a larger fraction of pearlite near slag particles.

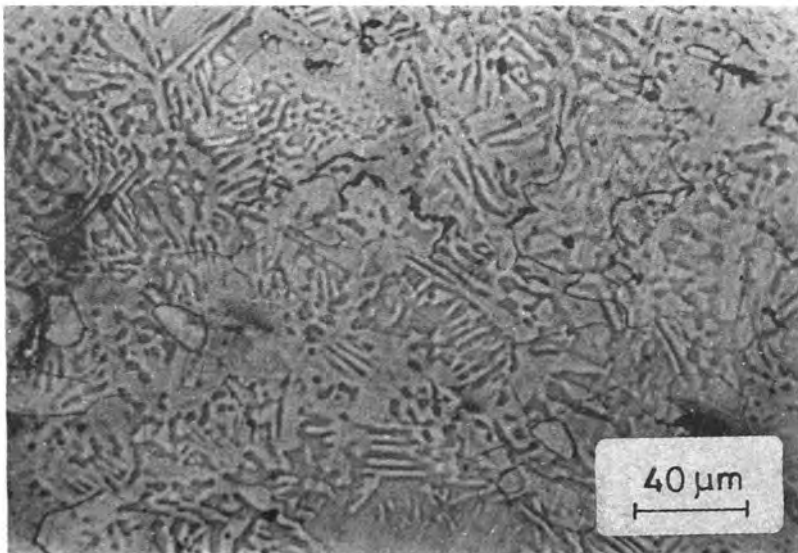

Fig. 18: Optical micrograph after nitral etch reveals “ghosting” effect that is typical of phosphorus containing iron.

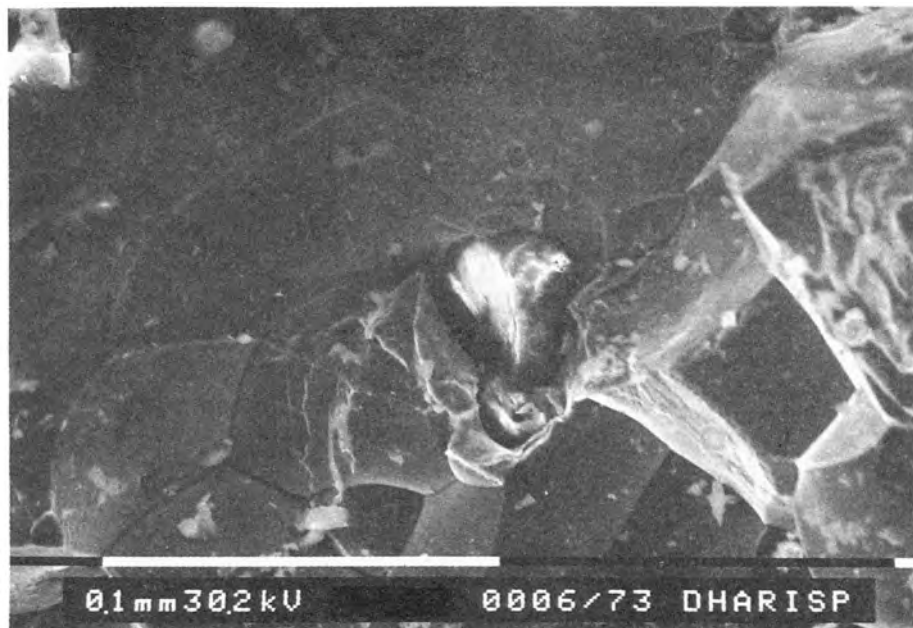

Fig. 19: Fracture surface of the Dhar pillar iron piece showing intergranular embrittlement due to phosphorus segregation to the grain boundaries.

Potentiodynamic polarization experiments were conducted with the Dhar pillar iron, Eran iron<sup>27</sup> and mild steel specimens in a borate buffered solution of pH 7.6. All the specimens exhibited stable passivity in the solution (Fig. 20). The Dhar pillar iron exhibited the lowest passive current density, thereby indicating its superior corrosion resistance. The pitting potential of the Dhar pillar iron was more active compared to that of mild steel and similar to that of Eran iron. This indicates the deleterious effect of the slag inclusions on passivity breakdown in both the ancient Indian irons<sup>27</sup>. The interfaces between the iron matrix and slag inclusions provide ideal initiation sites for pitting corrosion and hence the passive ranges in both Dhar pillar iron and Eran iron are lower compared to mild steel (Fig. 20).

In order to understand the atmospheric rusting process, samples of rust from the Dhar pillar iron piece were characterized by X-ray diffraction (XRD), Fourier transform infrared spectroscopy (FTIR) and Mössbauer spectroscopy<sup>23</sup>. XRD indicated that the rust from the atmospheric side of the sample consisted of magnetite ( $\text{Fe}_{3-x}\text{O}_4$ ), goethite ( $\alpha\text{-FeOOH}$ ),

lepidocrocite ( $\gamma$ -FeOOH) and phosphates while the rust from the other side consisted of magnetite, goethite and phosphates. The exact nature of phosphate could not be determined unambiguously from XRD, unlike the case of the Delhi iron pillar rust<sup>28</sup>.

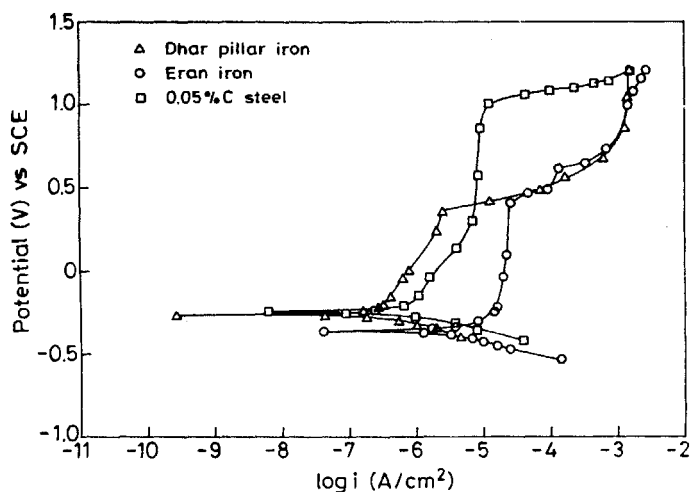

Fig. 20: Experimental potentiodynamic polarization diagrams for Dhar pillar iron, Eran iron and 0.05% C steel in borate buffered solution of pH 7.6.

The FTIR spectrum from the rust on the atmosphere side (Fig. 21) proves the presence of  $\alpha$ -Fe<sub>2</sub>O<sub>3</sub> (peak appearing at 572 cm<sup>-1</sup>),  $\gamma$ -FeOOH (peak appearing at 1023 cm<sup>-1</sup>),  $\delta$ -FeOOH (peak appearing at 884 cm<sup>-1</sup>) and  $\alpha$ -FeOOH (peak appearing at 465 cm<sup>-1</sup>). The broad band seen in the region 3000 cm<sup>-1</sup> to 3500 cm<sup>-1</sup> is due to hydration of the rust. It is known that O-H stretching leads to strong peak between 3000 cm<sup>-1</sup> to 3700 cm<sup>-1</sup> while O-H bending to a medium band between 1200 to 1500 cm<sup>-1</sup><sup>29,30</sup>. Therefore, this implies hydration of corrosion product(s) in the Dhar iron pillar rust. Misawa *et al*<sup>31,32</sup> attributed the following peaks as key absorption bands: 890 cm<sup>-1</sup> for  $\alpha$ -FeOOH, 1020 cm<sup>-1</sup> for  $\gamma$ -FeOOH, and 470 cm<sup>-1</sup> for  $\delta$ -FeOOH. Ishii and Nakahira<sup>33</sup> confirmed that the Fe-O stretching vibration in iron oxides corresponds to a wave number 570 cm<sup>-1</sup>. The peak appearing at 572 cm<sup>-1</sup> is indicative of Fe-O vibration in the oxide of iron. The exact nature of this oxide cannot be determined from the FTIR spectrum. However, the

exact nature of this was oxide was revealed by Mössbauer spectroscopy and therefore, it is possible to precisely attribute the Fe-O vibration to  $\alpha$ -Fe<sub>2</sub>O<sub>3</sub>.

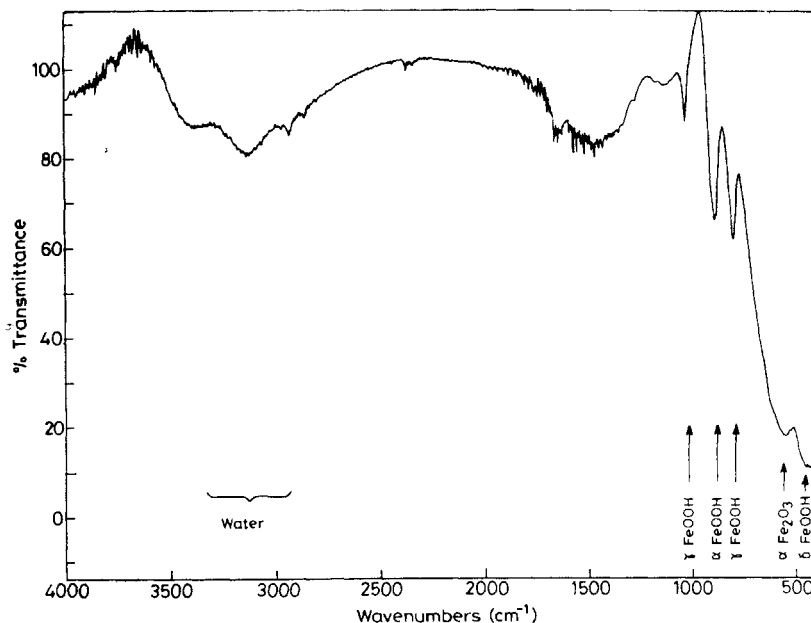

Fig. 21: Fourier transform infrared spectrum from Dhar iron pillar rust.

A shoulder in FTIR spectrum (Fig. 21) corresponding to phosphate ions could be discerned (1030 to 1120 cm<sup>-1</sup>) indicating that ionic phosphates were present in the rust that was studied. The wave numbers for ionic phosphate is 1030 to 1120 cm<sup>-1</sup>, while for covalent phosphate the band should occur at 920 to 1050 cm<sup>-1</sup> and for P=O bonds, the spectra occurs at 1200 to 1250 cm<sup>-1</sup><sup>29,30</sup>. It is difficult to conclude whether the ionic phosphate that is providing the signal in the spectra is due to H<sub>3</sub>PO<sub>4</sub> or FePO<sub>4</sub>. Nevertheless, FTIR spectroscopy proves the existence of phosphates in the Dhar iron pillar rust.

The relative amounts of  $\alpha$ -Fe<sub>2</sub>O<sub>3</sub> and  $\delta$ -FeOOH are high, as indicated by the larger peak intensities for these phases. The  $\delta$ -FeOOH phase forms due to catalytic action of elements like Cu, P, and Ni that are added for

weathering resistance<sup>31,32</sup>. The presence of  $\alpha\text{-Fe}_2\text{O}_3$  indicates the relatively stable nature of the rust<sup>34</sup>.

The Mössbauer spectrum (Fig. 22) is composed of two sextets and one central doublet. The experimental data points have been computer fitted to the line shown in Fig. 22. The sextets correspond to hematite ( $\alpha\text{-Fe}_2\text{O}_3$ ) and goethite as the hyperfine magnetic fields from the two sextets (518 kOe and 367 kOe) correspond precisely to the room temperature magnetic fields for these two phases<sup>35</sup>, respectively. The central doublet is indicative of the presence of  $\gamma\text{-FeOOH}$ ,  $\delta\text{-FeOOH}$  and maybe some superparamagnetic  $\alpha\text{-FeOOH}$ . The IS (isomer shift) for the central doublet is 0.468 mm/s and this is similar to that for  $\gamma\text{-FeOOH}$  while the QS (quadrupole splitting) for the doublet is 0.744 mm/s which is a little high and arises due to the water of hydration. It is interesting at this point to note that the IS and QS values were very low in the case of Delhi iron pillar rust<sup>28</sup> which is not generally observed.

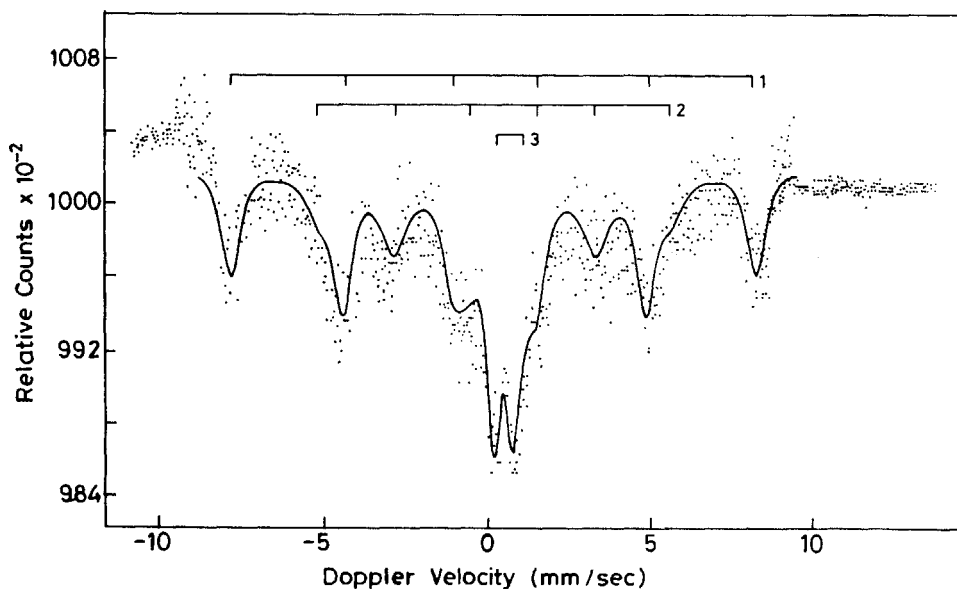

Fig. 22: Mössbauer spectrum from Dhar iron pillar rust.

In summary, the results of the characterization of the atmospheric rust of the Dhar iron pillar indicate the existence of crystalline  $\text{Fe}_{3-x}\text{O}_4$ ,  $\alpha\text{-}$

$\text{Fe}_2\text{O}_3$ ,  $\alpha\text{-FeOOH}$  and phosphate phases, and amorphous  $\gamma\text{-FeOOH}$  and  $\delta\text{-FeOOH}$  phases.

Cross sectional microscopy of the iron sample indicates that the atmospheric rust consisted of two layers, an optically dull inner thin layer and an optically bright thick outer layer (Fig. 23). The layered structure of the protective rust in the case of weathering steels is well established<sup>31,32,36</sup>. Regarding the optical nature of the layers on weathering steels, it has been pointed out that the inner optically isotropic layer of the surface rust is composed of X-ray amorphous spinel type iron oxide which can protect the steel matrix<sup>37,38</sup>. Yamashita *et al*<sup>36</sup> also observed, by microscopic observation using reflected polarized light and crossed nicols, that the rust layer present on a weathering steel exposed for 26 years could be divided into two parts: an outer layer which was optically active (i.e. illuminated) and an inner layer which was optically isotropic (darkened). On the other hand, the surface rust formed on mild steels consisted of the mottled structure consisting of the optically active and isotropic corrosion products<sup>36</sup>. It is also established that weathering steels obtain their protection due to the presence of the amorphous (dark) inner layer<sup>36</sup>. Therefore, based on the above studies, it is reasonable to state that the inner optically dull layer seen in the Dhar iron pillar rust microstructure is amorphous in nature while the outer layer is crystalline in nature. The innermost thin layer seen next to the metal surface must be the amorphous  $\alpha\text{-FeOOH}$  layer and this may be enriched with phosphorus or may contain crystalline phosphates, as has been found in corrosion-resistant ancient Indian iron<sup>39</sup>. The outer layer must consist of the usual corrosion products expected on atmospheric corrosion of iron (i.e. magnetite, hematite, goethite and lepidocrocite) and can also be enriched in phosphorus or contain phosphates. As the Dhar pillar iron contains a significant amount of phosphorus, the formation of phosphates is expected. The golden reddish brown color of the surface of the pillar pieces (see, for example, Fig. 17 of Ref. 4) also indicates that phosphates must be present in the atmospheric rust. The present analysis was performed from one of the pillars at a specific location and it is likely that the relative amount of phosphate in the rust at this location could have been low. Therefore, a detailed study of the rust from several locations of the three pillar pieces must be undertaken to elucidate the nature of the

protective passive film and its mechanism of formation. This is all the more important in the case of Dhar pillar iron because, as noted earlier, the three pillar pieces have been handled and shifted around several times during their history.

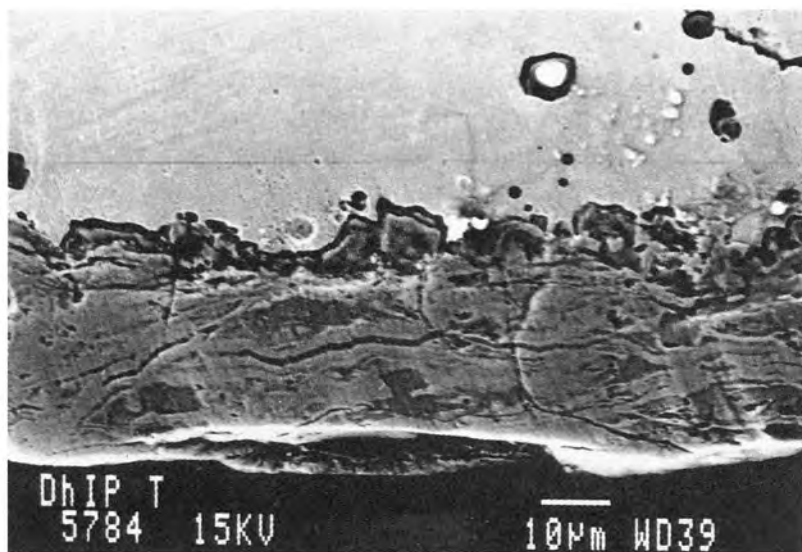

Fig. 23: Cross section of the atmospheric rust of the Dhar pillar iron showing an optically dull thin inner layer and an optically bright thick outer layer.

### CONCLUSIONS

Several new insights on the Dhar iron pillar have been obtained. The history of the pillar has been reviewed. The dimensions of the pillar have been analyzed. The original erection methodology of the pillar has been addressed. The microstructure of Dhar pillar iron is characteristic of ancient Indian iron, in that it contains entrapped fayalitic slag inclusions and a relatively high amount of phosphorus. The corrosion behavior of Dhar pillar iron has been compared with 0.5% C mild steel and another ancient Gupta period (6<sup>th</sup> Century AD) iron. The Dhar pillar iron exhibited lower passive current density in the borate buffered solution of pH 8.5. Samples of atmospheric rust from the Dhar iron pillar have been characterized by XRD, FTIR and Mössbauer spectroscopy. The existence of crystalline



$\text{Fe}_{3-x}\text{O}_4$ ,  $\alpha\text{-Fe}_2\text{O}_3$ ,  $\alpha\text{-FeOOH}$  and phosphate phases, and amorphous  $\gamma\text{-FeOOH}$  and  $\delta\text{-FeOOH}$  phases in the rust has been confirmed. Cross sectional analysis of the rust indicated a thin optically dull layer next to the metal-scale interface and a thick optically bright layer above this layer.

### ACKNOWLEDGEMENTS

The author gratefully acknowledges the co-operation extended by the Archaeological Survey of India in the study of the Dhar iron pillar.

### APPENDIX I: IRON PILLAR AT MANDU

An iron pillar currently stands in front of Jami Masjid at Mandu (Fig. 24). The history of this pillar is not known and further research is required. The following account of this iron pillar in front of the Jami Masjid at Mandu by a Bombay subaltern published in 1844 is interesting: "On the left, in front of the present quarters of some sepoy's of the Dhar Raja, is an iron pole now as a flagstaff." Führer<sup>15</sup> quotes in his Progress Report that this pillar was standing opposite to the Jami Masjid. Campbell<sup>17</sup>, in his account of



Fig. 24: The iron pillar in front of the Jami Masjid at Mandu.

Mandu, says: "In front of the gateway of the great mosque, in the center of a masonry plinth about 3 feet high, stands an iron pillar about a foot in diameter at the base and 20 feet high." When Cousens visited Mandu in February 1901, he noticed this tall iron pillar, wrapped round with an old flag. He further mentions that this iron pillar was known as Allaudin's *sang* (spear).

The pillar rests on a circular masonry platform. This platform rises 3'7" from the ground level. The iron pillar is embedded in the center of this platform. The pillar's diameter at the platform level is 11.8" while its total height is 11'5". At a height of 5' from the platform level, evidence of a joint can be noticed. The pillar exhibits a fairly smooth surface that does not show signs of severe corrosion. Moreover, the pillar surface exhibits a smooth polished surface especially in the lower regions due to contact with humans. In the upper regions, the surface is of reddish hue. It would be interesting to study the material of this pillar and the reason for its corrosion resistance. It would not be surprising if the pillar iron contained a significant amount of phosphorus, because, as seen earlier in the case of other ancient Indian iron, the relatively higher amount of phosphorus in ancient Indian iron often determines its corrosion resistance.

#### REFERENCES

1. Ghosh, M.K.: The Delhi Iron Pillar and Its Iron, *NML Technical J.*, 5 (1963), 31-45.
2. Balasubramaniam, R.: The Protective Passive Film of the Delhi Iron Pillar, *Bulletin of Metals Museum*, 34 (2001), 64-86.
3. Balasubramaniam, R.: Identity of *Chandra* and *Vishnupadagiri* of the Delhi Iron Pillar Inscription: Numismatic, Archaeological and Literary Evidence, *Bulletin of Metals Museum*, 32 (2000), 42-64.
4. Balasubramaniam, R.: Elucidation of Manufacturing Methodology Employed to Construct the Main Body of the Delhi Iron Pillar, *Bulletin of Metals Museum*, 31 (1999), 40-63.

5. Balasubramaniam, R.: On the Presence of Lead in the Delhi Iron Pillar, *Bulletin of Metals Museum*, 29.1 (1998), 19-39.
6. Balasubramaniam, R.: The Decorative Bell Capital of the Delhi Iron Pillar, *JOM*, 50.3 (1998), 40-47.
7. Balasubramaniam, R.: *Delhi Iron Pillar: New Insights*, Aryan Books International, New Delhi, 2002.
8. Smith, V.A.: Dhar Iron Pillar, *J. Roy. Asiatic Soc. of Great Britain and Ireland*, (1898), 143-146.
9. Choudhary, G.C.: *Political History of Northern India from Jain Sources (650 AD to 1300 AD)*, Sonalal Jaindharma Pracharak Samiti, Amritar, 1963, pp. 96-115.
10. *Imperial Gazetteer of India*, 11 (1908), 294-295.
11. Prakash, B.: Archaeometallurgical Study of Iron Pillar at Dhar, *Puratattva*, 20 (1989), 111-122.
12. Cousens, H.: The Iron Pillar at Dhar, *Archaeological Survey of India Annual Reports*, (1902-03), pp. 205-212.
13. Sohoni, S.V.: Historical Background of Iron Industry in Malwa of Bhoja's Period, *Society and Science*, 10 (1990), 104-109.
14. Biswas, A.K.: *Minerals and Metals in Ancient India*, Volume II, D.K. Printworld, New Delhi, 1996.
15. A. Führer, *Annual Report of the Archaeological Survey Circle, North-Western Provinces and Oudh for the Year ending 30th June 1893*, Thomson College Press, Rourkee, 1893, p. 21.
16. Beveridge, H.: *The Tuzuk-I-Jahangiri (The Memoirs of Jahangir)*, Volume I, Munshiram Manoharlal, New Delhi, 1968, pp. 406-408.
17. Campbell, J.: *J. Bombay Branch of the Royal Asiatic Society*, 19 (1895), 157.
18. Roessler, K.: The Non Rusting Iron Pillar at Dhar, *NML Tech. J.*, 37 (1995), 143-154.
19. Banerjea, J.N.: *The Development of Hindu Iconography*, Munshiram Manoharlal, New Delhi, 1956, p. 93.

20. Tylecote, R.F.: *A History of Metallurgy*, The Metals Society, London, 1979, p. 4.
21. Hadfield, R.: Sinhalese Iron and Steel of Ancient Origin, *J. Iron and Steel Inst.*, 85 (1912), 134-174.
22. Graves, H.G.: Further Notes on the Early Use of Iron in India, *J. Iron and Steel Inst.*, 85 (1912), 187-202.
23. Ramesh Kumar, A.V. and Balasubramaniam, R.: Corrosion Product Analysis of Dhar Pillar Iron, 2001, *unpublished work*.
24. Balasubramaniam, R.: On the Corrosion Resistance of the Delhi Iron Pillar, *Corrosion Sciences* 42 (2000), 2103-2129.
25. Stead, J.E.: Iron, Carbon and Phosphorus, *J. Iron and Steel Institute*, 91 (1915), 141-198.
26. Suzuki, S., Obata, M., Abiko, K. and Kimura, H.: Effect of Carbon on the Grain Boundary Segregation of Phosphorus in Alpha-Iron, *Scripta Metallurgica*, 17 (1983), 1325-1328.
27. Puri, V., Balasubramaniam, R. and Ramesh Kumar, A.V.: Corrosion Behaviour of Ancient 1500-year old Gupta Iron, *Bulletin of Metals Museum*. 28.2 (1997), 1-10.
28. Balasubramaniam, R. and Ramesh Kumar, A.V.: Characterization of Delhi Iron Pillar Rust by X-ray Diffraction, Fourier Infrared Spectroscopy and Mössbauer Spectroscopy, *Corrosion Science*, 42 (2000), 2085-2101.
29. Skoog, D.A. and Leary, J.J.: *Principles of Instrumental Analysis*, Fourth Edition, Harcourt Brace College Publishers, New York, 1992, p. 252-309.
30. Nyquist, R.A. and Kagel, R.A.: *IR Spectra of Inorganic Compounds*, Academic Press, New York, 1971.
31. Misawa, T., Kyuno, T., Suetaka, W. and Shimodaira, S.: The Mechanism of Atmospheric Rusting and the Effect of Cu and P on the Rust Formation of Low Alloy Steels, *Corrosion Science*, 11 (1971), 35-48.
32. Misawa, T., Asami, K., Hashimoto, K. and Shimodaira, S.: The Mechanism of Atmospheric Rusting and the Protective Amorphous Rust on Low Alloy Steel, *Corrosion Science*, 14 (1974), 279-289.
33. Ishii, M. and Nakahira, M.: Infrared Absorption Spectra and Cation Distributions in  $(\text{Mn,Fe})_3\text{O}_4$ , *Solid State Commn*, 11 (1972), 209-212.

34. Daniels, J.M. and Rosenewaig, A.: Mössbauer Spectroscopy of Stoichiometric and Non-stoichiometric Magnetite, *J. Phys. Chem. Solids*, 30 (1969), 1561-1571.
35. Vertes, A. and Czako-Nagy, I.: Mössbauer Spectroscopy and its Application to Corrosion Studies, *Electrochim. Acta*, 34 (1989), 721-758.
36. Yamashita, M., Miyuki, H., Matsuda, Y., Nagano, H. and Misawa, T.: The Long Term Growth of the Protective Rust Layer Formed on Weathering Steel by Atmospheric Corrosion During a Quarter of a Century, *Corrosion Science*. 36 (1994), 283-299.
37. Okada, H.: Atmospheric Corrosion of Steels, *J. Soc. Mater. Sci. Japan*, 17 (1968), 705-7709.
38. Okada, H., Hosoi, Y., Yukawa, K. and Naito, H.: Structure of the Rust Formed on Low Alloy Steels in Atmospheric Corrosion, *J. Iron Steel Inst. Japan*, 55 (1969), 355-365.
39. Dillmann, P. and Balasubramaniam, R.: Characterization of Protective Passive Film of Ancient Indian Iron using Microdiffraction Analyses, 2001, *to be published*.